



The Kenya Power &
Lighting Co. Ltd

TITLE:
**SPECIFICATION FOR
OVERHEAD LINE FITTINGS
PART 1: FITTINGS FOR 10-
300MM² CONDUCTORS**

Doc. No.	KPLC1/3CB/TSP/06/036-1
Issue No.	2
Revision No.	1
Date of Issue	2011-12-28
Page 1 of 11	

TABLE OF CONTENTS

0.1 Circulation List

0.2 Amendment Record

FOREWORD

1. SCOPE
2. REFERENCES
3. TERMS AND DEFINITIONS
4. REQUIREMENTS
5. TESTS AND INSPECTION
6. INSTRUCTIONS AND MARKING

ANNEX A: *Guaranteed Technical Particulars (to be filled and signed by the Manufacturer and submitted together with copies of manufacturer's catalogues, brochures, drawings, technical data, sales records, customer reference letters, details of manufacturing capacity & experience and copies of type test reports for tender evaluation)*

ANNEX B: *General Arrangement Drawings*

Issued by: Head of Section, Technical Stds & Specs

Authorized by: Head of Department, R&D

Signed: 

Signed: 

Date: 2011-12-28

Date: 2011-12-28



The Kenya Power & Lighting Co. Ltd

TITLE:
SPECIFICATION FOR
OVERHEAD LINE FITTINGS
PART 1: FITTINGS FOR 10-
300MM² CONDUCTORS

Doc. No.	KPLC1/3CB/TSP/06/036
Issue No.	2
Revision No.	1
Date of Issue	2011-12-28

Page 2 of 11

0.1 Circulation List

COPY NO.	COPY HOLDER
1	Research & Development Manager
2	Procurement Manager
Electronic copy (pdf) on KPLC Server (currently: Network→stima-fprnt-001→techstd&specs)	

0.2 Amendment Record

Rev No.	Date (YYYY-MM-DD)	Description of Change	Prepared by (Name & Signature)	Approved by (Name & Signature)
Issue 2 Rev 0	2011-12-28	Added 300mm ² AAAC in clause 4.2.1 and 24.71mm diameter in clause 4.3.3.1	G. Gathige <i>G. Gathige</i>	G.Owuor <i>G. Owuor</i>

Issued by: Head of Section, Technical Stds & Specs

Authorized by: Head of Department, R&D

Signed:

G. Gathige

Signed:

G. Owuor

Date: 2011-12-28

Date: 2011-12-28



The Kenya Power & Lighting Co. Ltd

TITLE:
SPECIFICATION FOR OVERHEAD LINE FITTINGS PART 1: FITTINGS FOR 10-300MM² CONDUCTORS

Doc. No.	KPLC1/3CB/TSP/06/036-1
Issue No.	2
Revision No.	1
Date of Issue	2011-12-28
Page 3 of 11	

FOREWORD

This specification has been prepared by the Research and Development Department of The Kenya Power and Lighting Company Limited (KPLC) and it lays down requirements for overhead line fittings for 10-150mm² conductors. The specification is to be used by KPLC in procurement of the items.

The bidder shall submit information which confirms the manufacturer's satisfactory service experience with products which fall within the scope of this specification.

1. SCOPE

- 1.1 This specification is for overhead line fittings for use on overhead power lines operating at voltages up to and including 66 kV (66,000 Volts) a.c. 50Hz.
- 1.2 This specification covers the following overhead line fittings:-
 - (a) Conductor terminations.
 - (b) Joints (Non-tension joints).
 - (c) Suspension clamps.
 - (d) Connectors (Line Taps)

Particular requirements for each type of fittings as may be relevant for a specific requisition are given in clause 4.

The specification also covers inspection and test of the overhead line fittings as well as schedule of Guaranteed Technical Particulars to be filled, signed by the manufacturer and submitted for tender evaluation.

The specification stipulates the minimum requirements for overhead line fittings acceptable for use in the company and it shall be the responsibility of the Supplier and Manufacturer to ensure adequacy of the design, good workmanship and good engineering practice in the manufacture of the fittings for KPLC.

The specification does not purport to include all the necessary provisions of a contract.

2. REFERENCES

The following standards contain provisions which, through reference in this text constitute provisions of this specification. Unless otherwise stated, the latest editions (including amendments) apply and shall be complied with by the supplier.

Issued by: Head of Section, Technical Stds & Specs

Authorized by: Head of Department, R&D

Signed:

Signed:

Date: 2011-12-28

Date: 2011-12-28



The Kenya Power &
Lighting Co. Ltd

TITLE:
**SPECIFICATION FOR
OVERHEAD LINE FITTINGS
PART 1: FITTINGS FOR 10-
300MM² CONDUCTORS**

Doc. No.	KPLC1/3CB/TSP/06/036
Issue No.	2
Revision No.	1
Date of Issue	2011-12-28
Page 4 of 11	

- ISO 1461: Metallic Coatings – Hot dip galvanized coatings on fabricated ferrous products – Requirements.
- IEC 61284: Overhead Lines – Requirements and Test for Fittings.
- BS 3288: Insulator and Conductor Fittings for Overhead Power Lines.
- ESI 43-92: Conductor Terminations, Joints and Insulator Binds for Overhead Lines up to and including 132 kV.

3. TERMS AND DEFINITIONS

The definitions given in the reference standards apply.

4. REQUIREMENTS

4.1 SERVICE CONDITIONS

The fittings shall be suitable for continuous operation outdoors in tropical areas at altitudes of up to 2200m above sea level, humidity of up to 90%, average ambient temperature of +30°C with a minimum of -1°C and a maximum of +40°C and heavy saline conditions along the coast.

4.2 DESIGN AND CONSTRUCTION

- 4.2.1 The fittings shall be designed and manufactured to IEC 61284, BS 3288 and the requirements of this specification and shall be suitable for use on 25-150mm² Aluminium Conductor Steel Reinforced (ACSR), 50-100mm² All Aluminium Conductor (AAC), 50-300mm² All Aluminium Alloy Conductor (AAAC), 16-300mm² Aluminium Cables and where specified 10-100mm² Copper Conductor/Cable (tap).
- 4.2.2 The fittings shall be free from defects which would likely cause them to be unsatisfactory in service.
- 4.2.3 All parts of each fitting shall be inherently resistant to atmospheric corrosion, both during storage and in service.
- 4.2.4 All ferrous metal parts except those made of stainless steel shall be protected by hot dip galvanizing as per the requirement of ISO 1461. The minimum average coating weight for any individual test area shall be not less values given in ISO 1461.

Issued by: Head of Section, Technical Stds & Specs

Authorized by: Head of Department, R&D

Signed:

Signed:

Date: 2011-12-28

Date: 2011-12-28



The Kenya Power &
Lighting Co. Ltd

TITLE:

**SPECIFICATION FOR
OVERHEAD LINE FITTINGS
PART 1: FITTINGS FOR 10-
300MM² CONDUCTORS**

Doc. No.

KPLC1/3CB/TSP/06/036-1

Issue No.

2

Revision No.

1

Date of Issue

2011-12-28

Page 5 of 11

4.2.5 The threads of nuts and tapped holes shall be cut after galvanizing and shall be well oiled or greased. All other threads shall be formed before galvanizing.

4.2.6 General arrangement drawings for the various types of fittings will be attached in Annex B of this specification. Drawings for fittings with BS 3288 Reference Numbers are available in the standard.

4.3 PARTICULAR REQUIREMENTS

4.3.1 Conductor Terminations

4.3.1.1 *Ball Ended Hook, Socket Clevis and Socket Tongue*

- (a) Ball ended hook, socket clevis and socket tongue shall be suitable for use on Aluminium Conductor Steel Reinforced (ACSR) of outer diameter between 7.00mm and 18.2mm (25mm² and 150mm²) and standard disc insulator of ball and socket type with the ball pin diameter of 16 mm.
- (b) Ball ended hook, socket clevis and socket tongue shall be of malleable iron or ductile iron, hot dip galvanized to ISO 1461.
- (c) Ball ended hook, socket clevis and socket tongue shall be as per BS 3288 Reference Numbers given below:

Description	BS 3288 Reference Number
Ball ended hook	15/81
Ball clevis	15/83
Socket clevis, single hole	15/84
Socket clevis, double hole	15/25
Socket tongue, single hole	15/85
Socket tongue, double hole	15/35

Note: Drawings for Ball Ended Hook, Socket Clevis and Socket Tongue shall be as per BS 3288.

4.3.1.2 *Tension clamp (Gun Clamp)*

- (a) Tension Clamp shall be bolted type and shall be suitable for use on Aluminium Conductor Steel Reinforced (ACSR) of outer diameter between 7.00mm and 18.2mm (25mm² and 150mm²).

Issued by: Head of Section, Technical Stds & Specs

Authorized by: Head of Department, R&D

Signed:

Signed:

Date: 2011-12-28

Date: 2011-12-28



The Kenya Power &
Lighting Co. Ltd

TITLE:
**SPECIFICATION FOR
OVERHEAD LINE FITTINGS
PART 1: FITTINGS FOR 10-
300MM² CONDUCTORS**

Doc. No.	KPLC1/3CB/TSP/06/036-1
Issue No.	2
Revision No.	1
Date of Issue	2011-12-28
Page 6 of 11	

- (b) The clamp body and keeper piece shall be of high strength and heat treated cast aluminium alloy.
- (c) The clamp cotter bolts, and U-bolts shall be galvanized steel and the pin shall be stainless steel. The number of bolts shall be 3 or 4 (to be stated in the tender).
- (d) The clamp shall have slip strength of not less than 85% of the rated ultimate strength of conductor it is intended for use with.

4.3.2 Suspension Clamps

Suspension clamps shall be suitable for use on Aluminium Conductor Steel Reinforced (ACSR) of outer diameter between 7.00mm and 18.2mm (25mm² and 150mm²).

- (a) *Clevis ended hook type, tongue ended hook type and pivoted type* (similarly known as *envelope type* and *trunnion type* respectively).
 - (i) The clamp body and keeper piece shall be of high strength, heat-treated cast aluminium alloy.
 - (ii) The clamp cotter bolts, hangers, brackets and U-bolts shall be of galvanized steel and the cotter pin shall be of stainless steel.
- (b) *Angle suspension clamp type* (similarly known as *side opening type*).
 - (i) The clamp shall be suitable for use on turning angles from 10 to 120 degrees.
 - (ii) The clamp body and keeper shall be of malleable iron or ductile iron, hot dip galvanized.
 - (iii) The clamp cotter bolts and bolt shall be galvanized steel and the cotter pin shall be stainless steel.

4.3.3 Joints (Non-tension)

4.3.3.1 *Parallel Groove Clamp (PG Clamp)*

- (a) PG Clamp shall be suitable for use on aluminium conductor steel-reinforced and all aluminium conductors of outer diameter in the range of 7.00 mm to 18.2 mm for ACSR conductors, 9.0 mm to 13.2 mm for AAC conductors and 24.71mm for AAAC.

Issued by: Head of Section, Technical Stds & Specs

Authorized by: Head of Department, R&D

Signed:

Signed:

Date: 2011-12-28

Date: 2011-12-28



The Kenya Power &
Lighting Co. Ltd

TITLE
**SPECIFICATION FOR
OVERHEAD LINE FITTINGS
PART 1: FITTINGS FOR 10-
300MM² CONDUCTORS**

Doc. No.	KPLC1/3CB/TSP/06/036-1
Issue No.	2
Revision No.	1
Date of Issue	2011-12-28
Page 7 of 11	

- (b) The groove of the PG clamp shall correctly fit the conductor it is intended for use with. It shall have adequate cross sectional area and length.
- (c) The PG clamp shall be of electrolytic, high strength, corrosion resistant aluminium alloy.
- (d) Connectors for connecting aluminium conductor to copper conductor shall have pressure welded copper inserts in the tap-off side. The tap conductor shall be of size 10 – 95mm².
- (e) The number of bolts shall be 2, 3 or 4 (to be stated in tender)
- (f) The PG Clamps shall be as per drawings attached.

4.3.3.2 Connectors (Line Taps)

- (a) The connectors shall be suitable for use on stranded bare conductors and shall correctly fit the conductor it is intended for use.
- (b) The connector shall have adequate cross sectional area and dimensions and shall have current carrying capacity at least equal to the capacity of the conductor it is intended for.
- (c) *Aluminium connectors (Aluminium Line Taps)*
 - (i) Aluminium connectors (line taps) shall be suitable for connecting stranded aluminium conductors of sizes 50mm² and 100mm².
 - (ii) The connector shall be manufactured from electrolytic, high strength aluminium.
 - (iii) Aluminium line taps shall be as per drawing attached.
- (d) *Copper connectors (copper line taps)*
 - (i) Copper connectors shall be suitable for connecting stranded copper conductors of sizes 10 – 95mm².
 - (ii) The connector shall be manufactured from high strength cast copper alloy (high copper content) with tinned finish.

Issued by: Head of Section, Technical Stds & Specs

Signed:

Date: 2011-12-28

Authorized by: Head of Department, R&D

Signed:

Date: 2011-12-28



The Kenya Power &
Lighting Co. Ltd

TITLE:
**SPECIFICATION FOR
OVERHEAD LINE FITTINGS
PART 1: FITTINGS FOR 10-
300MM² CONDUCTORS**

Doc. No.	KPLC1/3CB/TSP/06/036-1
Issue No.	2
Revision No.	1
Date of Issue	2011-12-28
Page 8 of 11	

(iii) Dimensions shall be to Drawing No. TSP/06/26-001 REV 1 and the table below:

Conductor size/ Dimension (mm)	A	B	C	D
10 – 25MM ²	30	6.5	16	20
25 – 70MM ²	42	12	24	32
750 – 120MM ²	55	15	30	37
150MM ²	74	19	48	52

(e) *Bi-metal connectors (Bi-metal Line Taps)*

- (i) Bi-metal connectors shall be suitable for connecting stranded aluminium conductors of sizes 50mm² and 100mm² to stranded copper conductors of sizes 10 – 70mm².
- (ii) The bi-metal connector shall be designed to provide an effective corrosion barrier between the dissimilar metals (aluminium and copper).

5. TESTS AND INSPECTION

- 5.1 The fittings shall be inspected and tested in accordance with the requirement of IEC 61284, BS 3288 and this specification. It shall be the responsibility of the manufacturer to perform or to have performed all the tests specified.
- 5.2 Copies of previous Type Test Reports issued by an independent and ISO/IEC 17025 accredited testing laboratory shall be submitted with the tender for the purpose of technical evaluation, all in English language.

Copies of Test Reports (to IEC 61284, BS 3288-1) to be submitted shall include the results of the appropriate type tests made on not less than three fittings identical in all essential details with those to be supplied; and shall include the following:

- Mechanical Type Tests
- Electrical Type Tests (Resistance and Electrical Heating Cycle Test)

- 5.3 Complete Test Reports for Sample & Routine Tests to IEC 61284 and BS 3288 for each item shall be submitted to The Kenya Power and Lighting Company for approval before shipment and delivery.

The test reports shall include:

- Verification of Dimensions
- Mechanical Type Tests

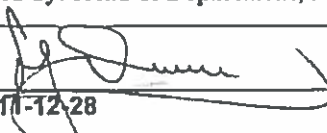
Issued by: Head of Section, Technical Stds & Specs	Authorized by: Head of Department, R&D
Signed: 	Signed: 
Date: 2011-12-28	Date: 2011-12-28



The Kenya Power & Lighting Co. Ltd

TITLE:
**SPECIFICATION FOR
OVERHEAD LINE FITTINGS
PART 1: FITTINGS FOR 10-
300MM² CONDUCTORS**

Doc. No.	KPLC1/3CB/TSP/06/036-1
Issue No.	2
Revision No.	1
Date of Issue	2011-12-28
Page 9 of 11	

▪ **Electrical Type Tests (Resistance and Electrical Heating Cycle Test)**

5.4 On receipt of the conductor fittings/accessories, KPLC will inspect them and may perform or have performed any of the relevant tests in order to verify compliance with the specification. The supplier shall replace/rectify without charge to KPLC, items which upon examination, test or use fail to meet any or all of the requirements in the specification.

6. INSTRUCTIONS & MARKING

6.1 Each item shall be marked (during manufacture) legibly and indelibly with the following information.

- a) Manufacturer's identity
- b) Type reference number
- c) Applicable conductor sizes (mm²)

6.2 Instructions for installation and details on applicable tools shall be included in each package, all in English Language.

----- THIS SPACE LEFT BLANK -----

Issued by: Head of Section, Technical Stds & Specs

Authorized by: Head of Department, R&D

Signed:

Signed:

Date: 2011-12-28

Date: 2011-12-28



The Kenya Power & Lighting Co. Ltd

TITLE:
SPECIFICATION FOR OVERHEAD LINE FITTINGS PART 1: FITTINGS FOR 10-300MM² CONDUCTORS

Doc. No.	KPLC1/3CB/TSP/06/036-1
Issue No.	2
Revision No.	1
Date of Issue	2011-12-28
Page 10 of 11	

ANNEX A: *Guaranteed Technical Particulars (to be filled and signed by the Manufacturer and submitted together with copies of manufacturer's catalogues, brochures, drawings, technical data, sales records, customer reference letters, details of manufacturing capacity & experience and copies of type test reports for tender evaluation)*

Tender No.

Clause number	Bidder's offer (indicate full details of the offered item for each requirement of the specification)
1 (1.1 – 1.2)	
2	
3	
4.1	
4.2.1	
4.2.2	
4.2.3	
4.2.4	
4.2.5	
4.2.6	
4.3.1.1	
4.3.1.2	
4.3.2 (a) – (b)	
4.3.3.1 (a) – (f)	
4.3.3.2 (a) – (e)	
5.1	
5.2	
5.3	
5.4	
6.1	
6.2	

.....
Manufacturer's Name, Signature, Stamp and Date

Issued by: Head of Section, Technical Stds & Specs	Authorized by: Head of Department, R&D
Signed:	Signed:
Date: 2011-12-28	Date: 2011-12-28



The Kenya Power &
Lighting Co. Ltd

TITLE:

SPECIFICATION FOR
OVERHEAD LINE FITTINGS
PART 1: FITTINGS FOR 10-
300MM² CONDUCTORS

Doc. No.

KPLC1/3CB/TSP/06/036-1

Issue No.

2

Revision No.

1

Date of Issue

2011-12-28

Page 11 of 11

ANNEX B: General Arrangement Drawings (ATTACHED)

Issued by: Head of Section, Technical Stds & Specs

Authorized by: Head of Department, R&D

Signed:

Signed:

Date: 2011-12-28

Date: 2011-12-28

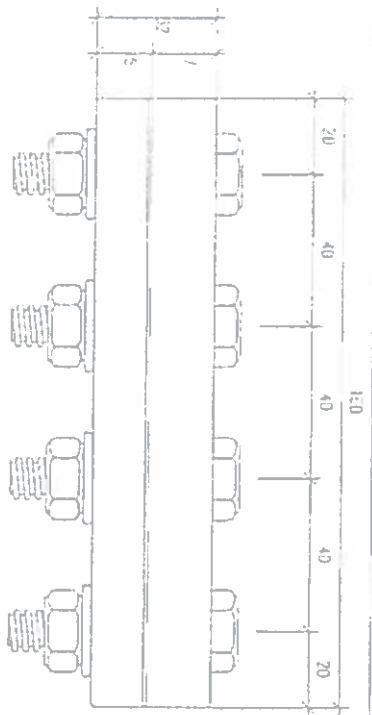

SIDE ELEVATION

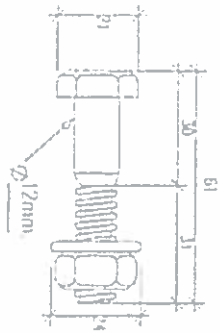

BOLT, WASHER AND NUT ELEVATIONS

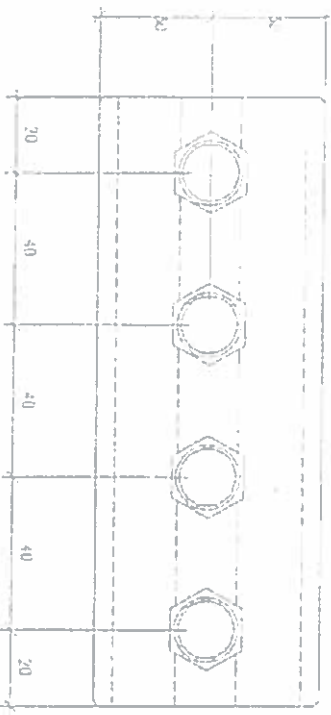

TOP ELEVATION

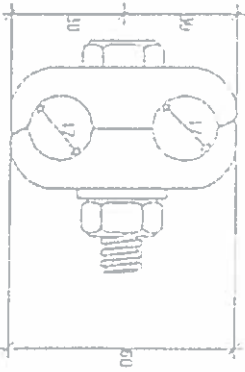

SIDE ELEVATION

Materials :-
PG Clamp: high strength, corrosion resistant aluminum alloy.
Bolts: strength grade designation 8.8 to BS 4190 and hot dip galvanized to ISO 1461.

Handwritten signature and date:
 2011-03-24
 2011-03-24

REV	DATE	BY	CHKD	APPD
01				

NO	DESCRIPTION	QTY	UNIT	REMARKS

PARALLEL GROOVE CLAMP (4Bolts)

K.P.&L CO. Ltd
 TSP/06/036-1-1

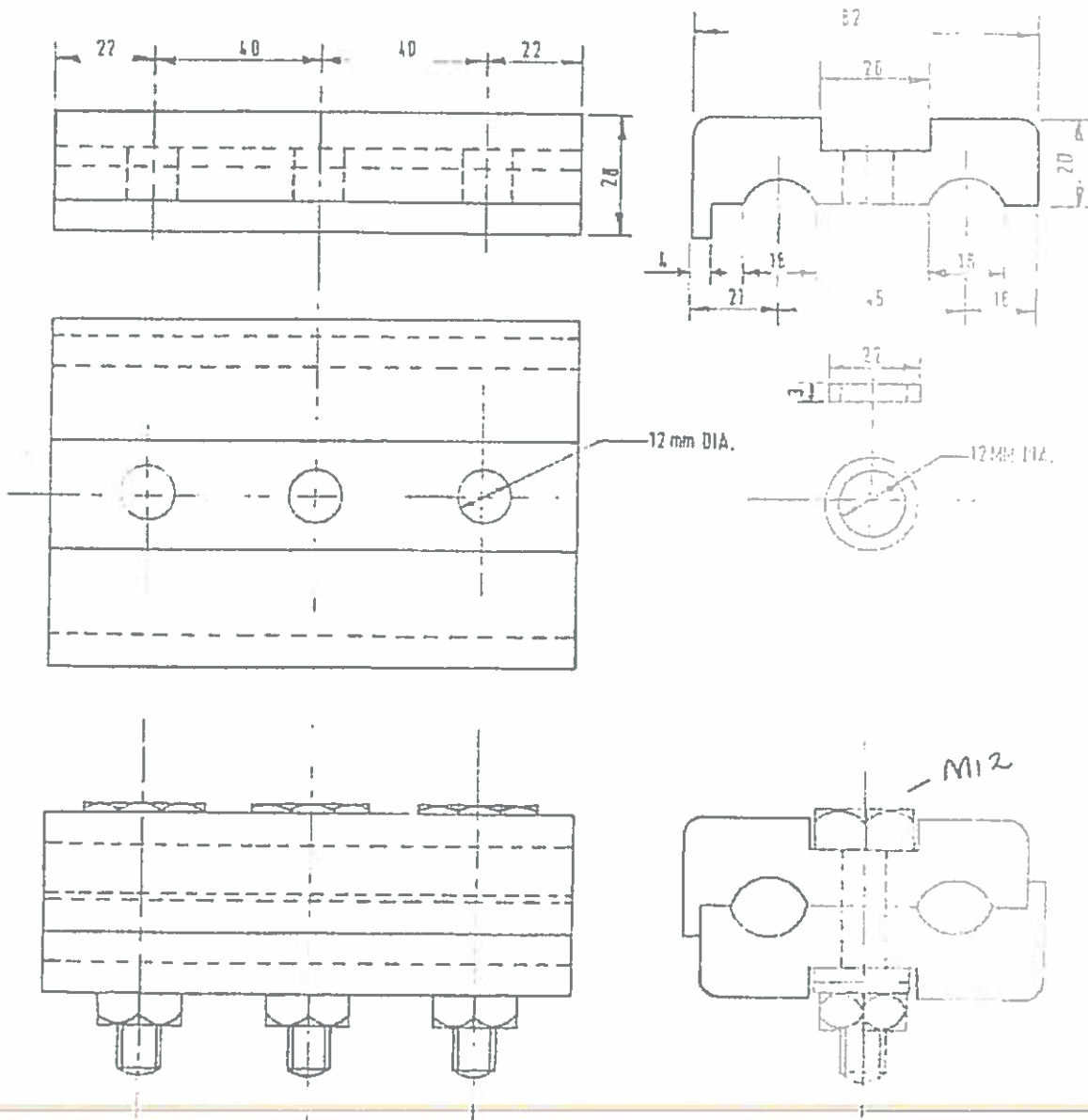

(Signature)
25/11/24

SK. No.
2071-03-24

DRAWN	D.05 HLA	DETAILS OF P.G. CLAMP (35/11) K. P. & L. CO LTD
TRACED		
CHECKED		SK. No.
APPROVED		
		NOT TO SCALE

$\frac{5}{8}$ " X $2\frac{1}{4}$ " BOLT
 115 X 76

$\frac{11}{16}$ "
 17

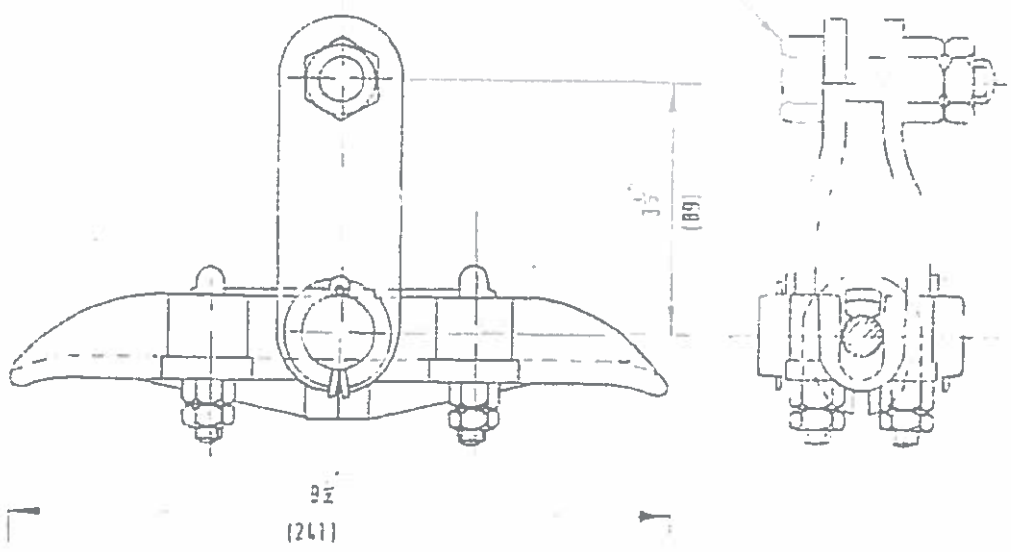

PIVOTED TYPE SUSPENSION CLAMP

Signature
 2011-03-24

SCALE		ISSUE	ISSUE	ISSUE	ISSUE	K. P. & L. Co. Ltd. 11KV / 33KV
DATE	10 9 03					
DRAWN	V. G. G. n					
CHECKED						
APPROVED						

Signature
 2011/03/24

FRONT ELEVATION

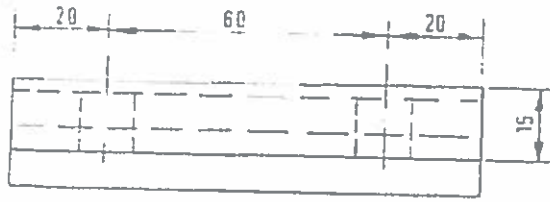

END ELEVATION

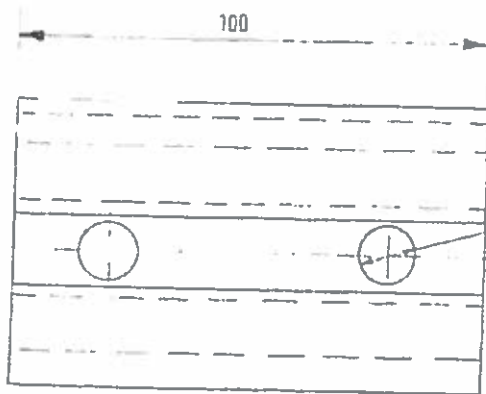
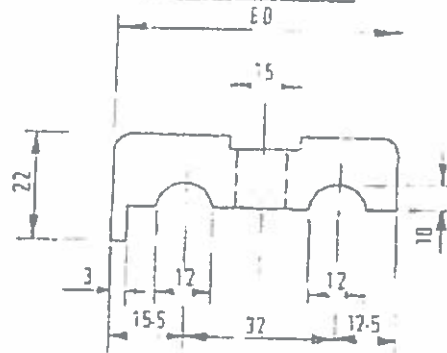

PLAN

DIA 11 mm



DIA 15 mm

RECTANGULAR WASHER

P. G. CLAMP (2 OFF,

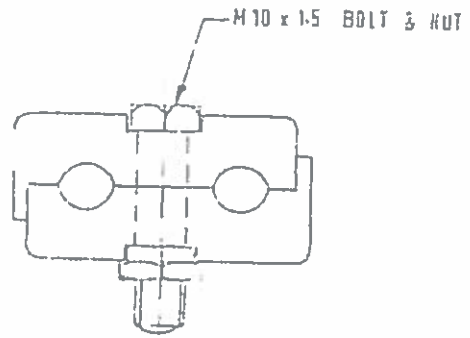
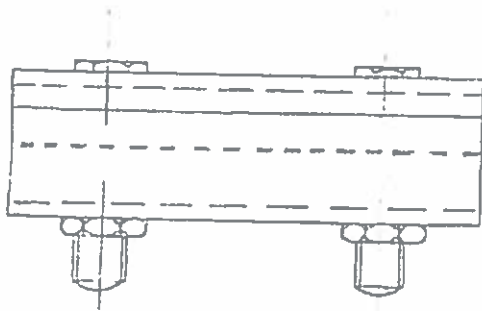

ASSEMBLY

Signature
2011/3/24

Signature
2011-03-24

DETAILS OF P. G. CLAMP (2 bolts)

SCALE	1 : 15	ISSUE	ISSUE	ISSUE	ISSUE
DATE	21.2.94				
DRAWN	M OKOTH				
TRACED					
CHECKED					
APPROVED					

K. P. & L. Co. Ltd.

11KV /

LINE TAP	A	B	C	D	E	F	G	H	J	K	L	M	N	O	P	Q	R	S	T
FOR 30NH ² AAC	18	6	36	20	2.5	8	22	19	3	8	12	16	8	14	10	3	8	8	8
FOR 180NH ² AAC	48	20	96	56	6	24	55	48	9	24	36	48	24	72	48	12	24	24	24

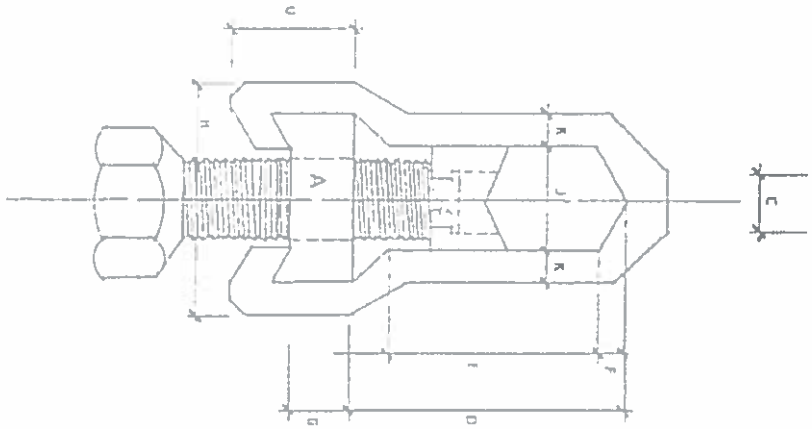

SIDE

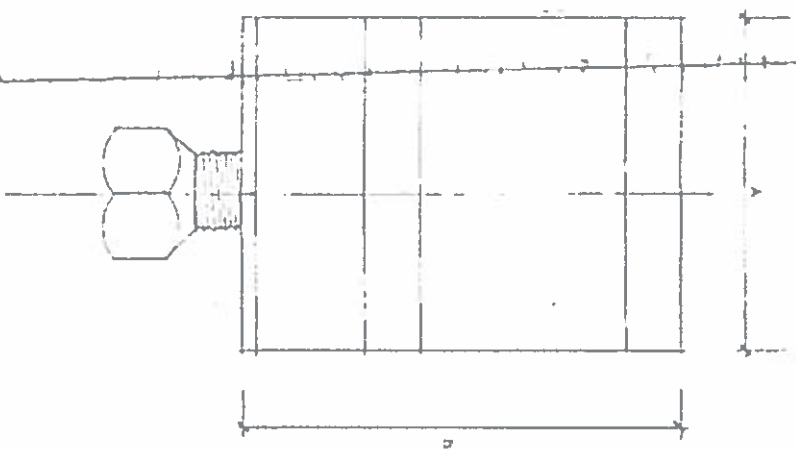

FRONT

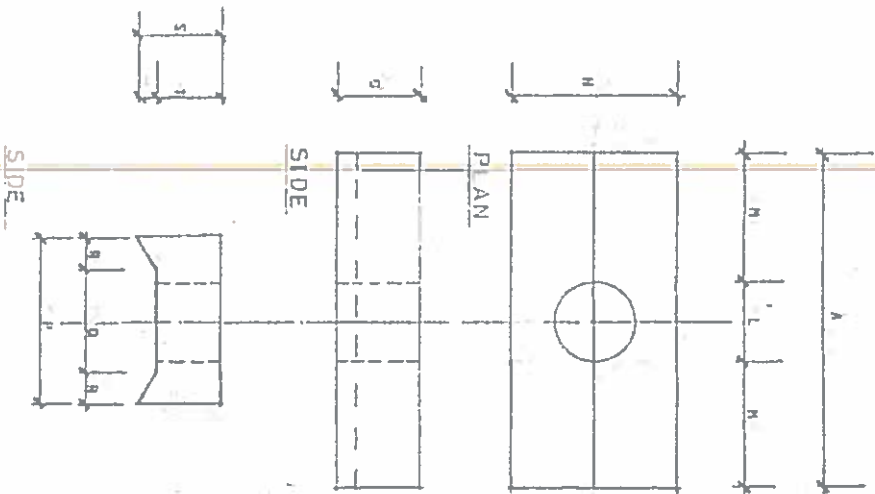

PLAN

SIDE

SIDE

DETAIL A

SCALE	1.50	REVISION	DATE	SIGN	CHECKED
DATE	2.10.09				
DRAWN	VALI S				
APP					

DETAIL OF LV LINE TAP FOR CONDUCTOR SIZE 0.05" & 0.1"

KPL&Co. LTD

(Signature)
2011/8/24
201-03-24

MATERIALS:
 HIGH STRENGTH CAST COPPER ALLOY
 (HIGH COPPER CONTENT), TINNED FINISHED,
 PRESSURE PADS WITH SERRATED SURFACE.

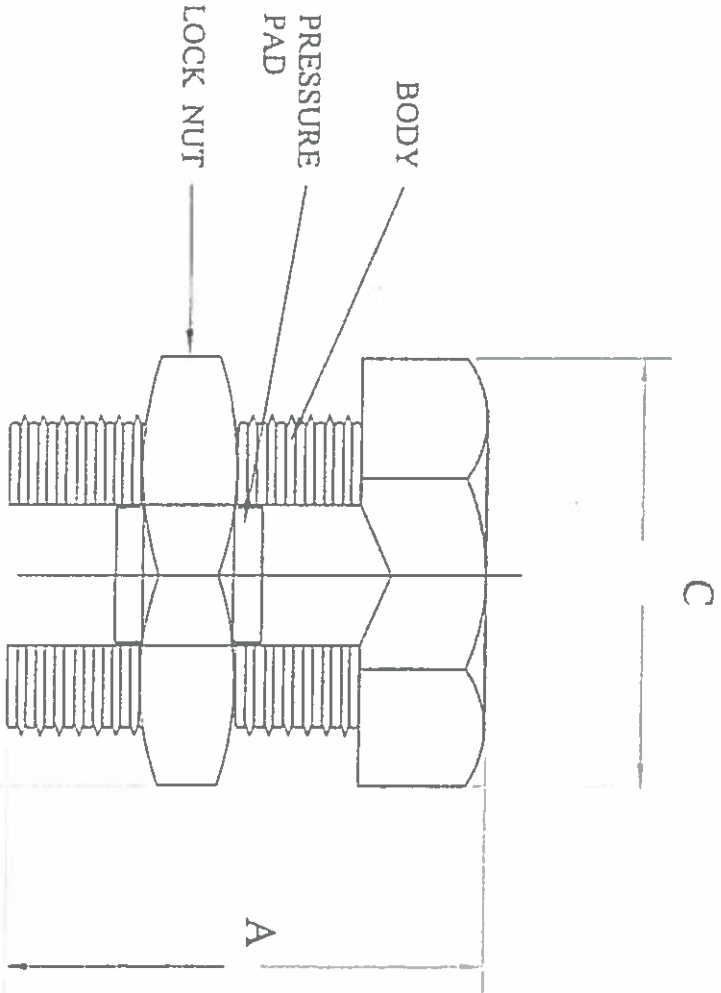

Dimensions	A	B	C	D
Dimensions as per specifications				

for
 2011-03-24
(b) atty
 2011/3/24

APPROVED	DATE
DESIGNED	DATE
CHECKED	DATE
DATE	
DATE	

REV	REVISION	DATE	APP	DESIGN	DATE

SPLIT BOLT(COPPER LINE TAP)

K. P. & L. Co. Ltd
 TSP /06/ 26-001 REV 1



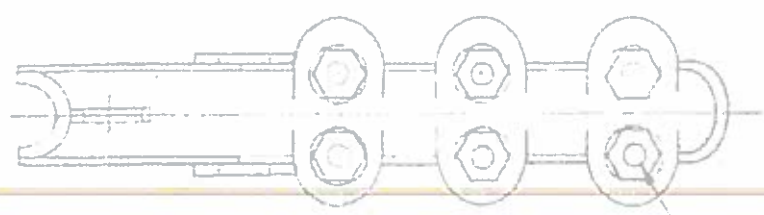
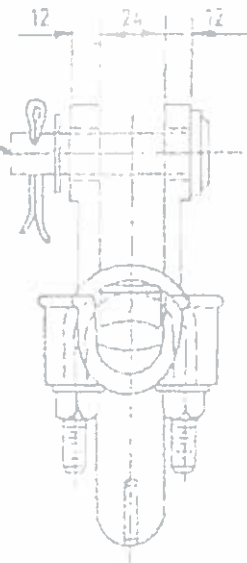
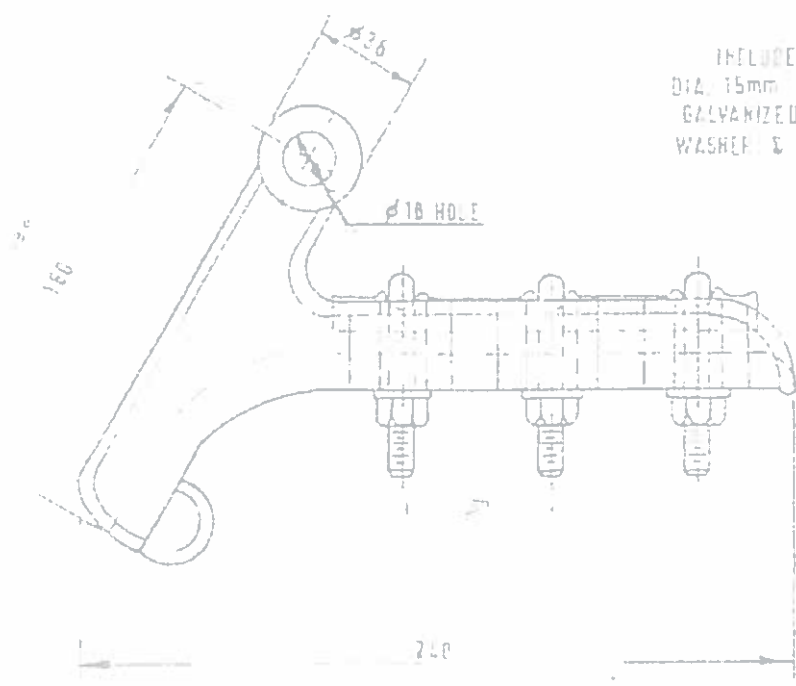
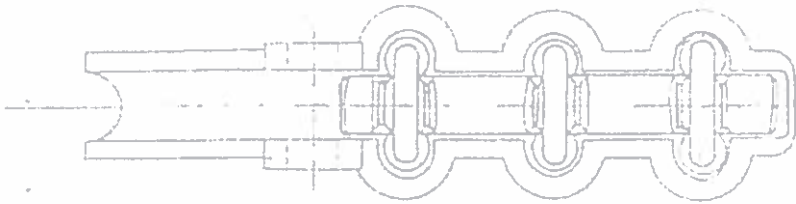

12 mm DIA. MS. GALVANIZED
U-BELTS WITH 2 NUTS

l. abhy
Sanfe
2011-03-24
2014/3/24

TENSION CLAMP (36=1/3)

APPROVED		ISSUE	ISSUE	ISSUE	ISSUE	K. P. & L. Co. Ltd.
BY						
E	22-02-95					
WH	M. Ekath					
CE						
LE	1:2.5 (mm)					

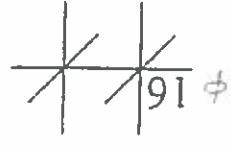
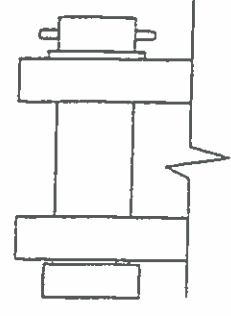
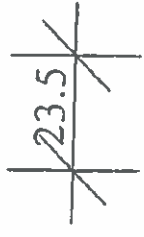
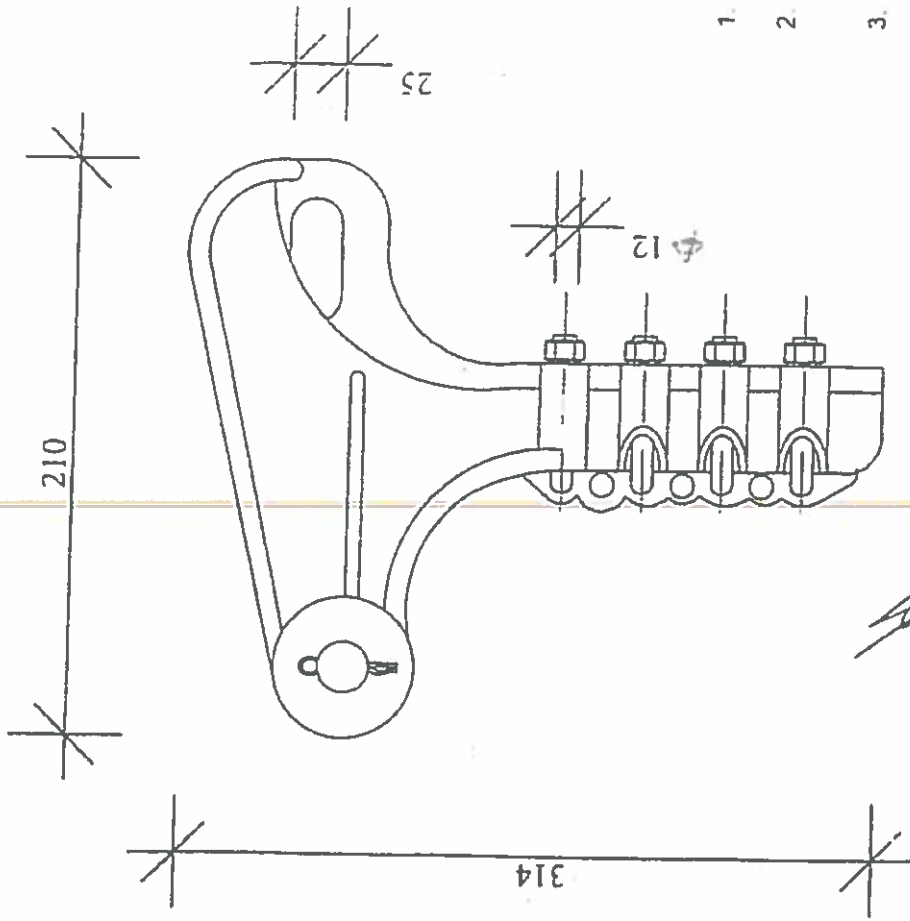

NOTES

1. Clamps shall be cast aluminium alloy to BS 1490 The associated clamping plate shall be of 99.5 per cent purity aluminium
2. Clamping bolts U-bolts and nuts shall comply with the requirements of BS 3692 and shall be hot-dip galvanized to BS 729. The minimum strength grade designations for bolts and nuts shall be 8.8 and 8 respectively.
3. Sockets shall be 16mm B, to Table 4 of BS 3288 Part 2. Clevis shall be to BS 3288, Part 2.
4. All clamps shall be provided with facilities for attaching tensioning equipment to the loading end of the clamp, with an MFL equal to that of the fitting and large enough to accept a 16mm pin.
5. Steel shall be of a quality which will not be adversely affected by the galvanizing process.

Handwritten signature
 2011-03-24
 (A. J. J. J.)
 2011/11/15

APPROVED	
CHECKED	2011-03-24
DRAWN	J.M. LAHARR
DATE	20/01/05

TENSION CLAMP (4 bolts)

K. P. & L. Co. LTD

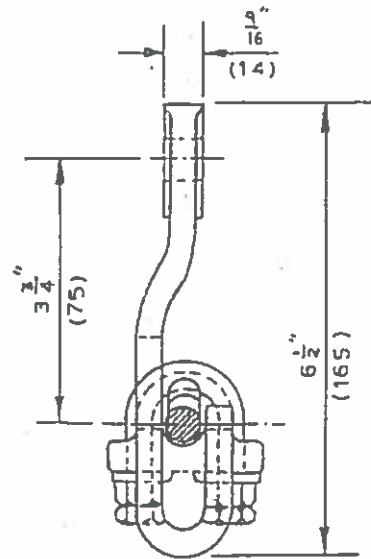
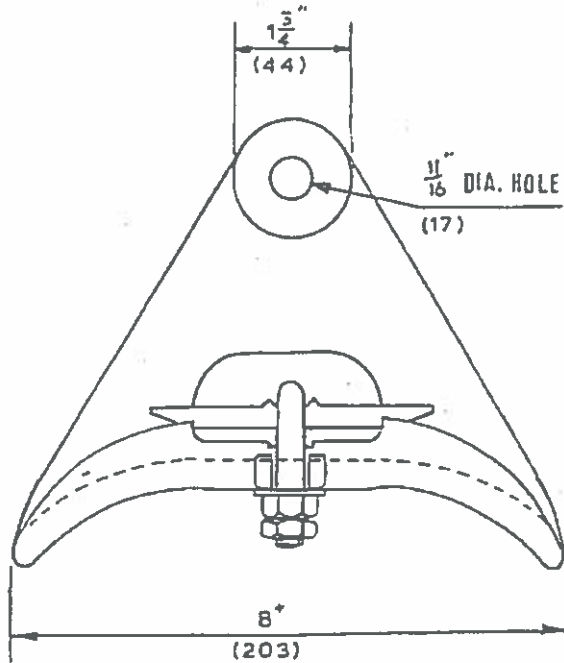

TONGUE ENDED HOOK TYPE SUSPENSION CLAMP

$\frac{5}{8}$ " DIA. THROUGH PIN
(16)

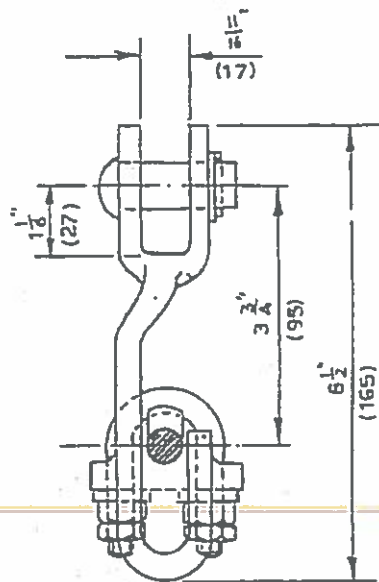
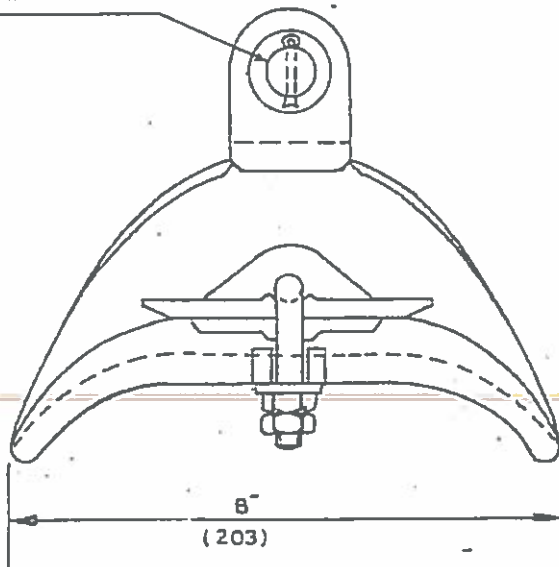

CLEVIS ENDED HOOK TYPE SUSPENSION CLAMP

Handwritten signature
2011-03-22
2011/3/24